

INSTRUMENT AERODROME ELEV. 3266 FT
APPROACH HEIGHTS RELATED TO
CHART-ICAO THR RWY 31R ELEV. 3260 FT

APP 127.300
RADAR 127.300
TWR 118.100, 121.900
GND 121.700
ATIS 126.400

MASHHAD/SHAHID HASHEMI NEJAD
ILS 1 RWY 31R
CAT A/B/C/D

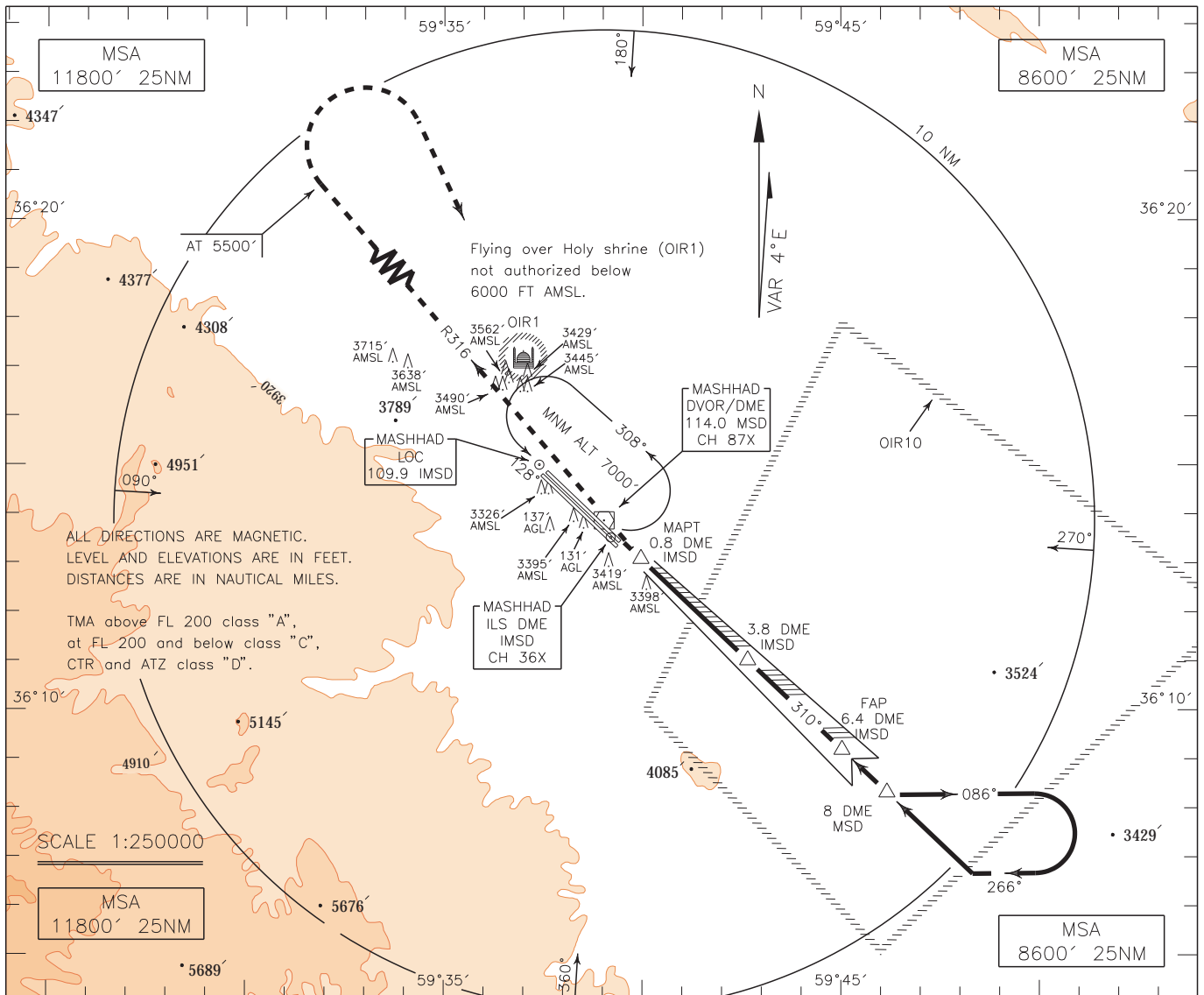

MISSED APPROACH: At 0.8 DME(IMSD) turn right climb on RDL 316 to 5500 FT, then turn right to
rejoin HLDG at 7000 FT.

TA 8000'

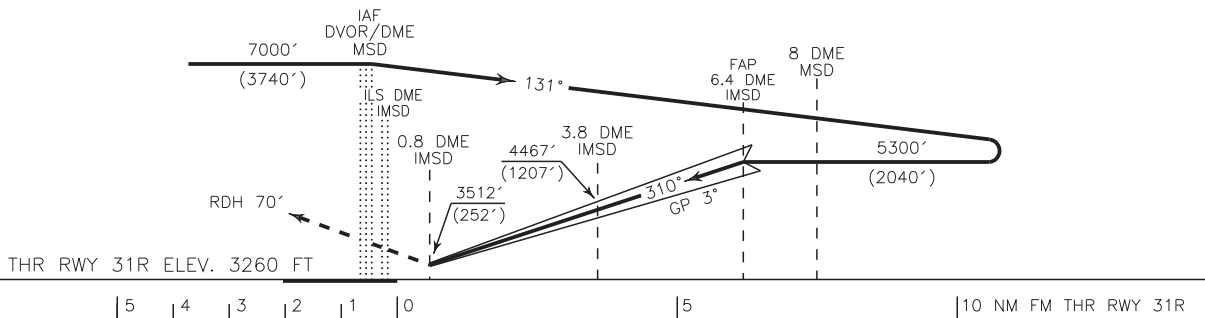

NOTE:

- 1-Circling not authorized BTN RDL 150 and RDL 300 clockwise direction.
- 2-Contour intervals are to be selected at 990 FT (300 M).

OCA(H)	A	B	C	D
Straight		3512' (252')		
GP INOP		3630' (370')		
Circling		3960' (694')		