

INSTRUMENT APPROACH CHART-ICAO
AERODROME ELEV. 4927 FT
HEIGHTS RELATED TO THR RWY 29L ELEV. 4870 FT

RADAR 119.000-125.400
APP 119.000-125.400
TWR 118.100
GND 121.900
ATIS 127.000

SHIRAZ/SHAHID DASTGHAIB
ILS Z
RWY 29L
CAT A/B/C/D

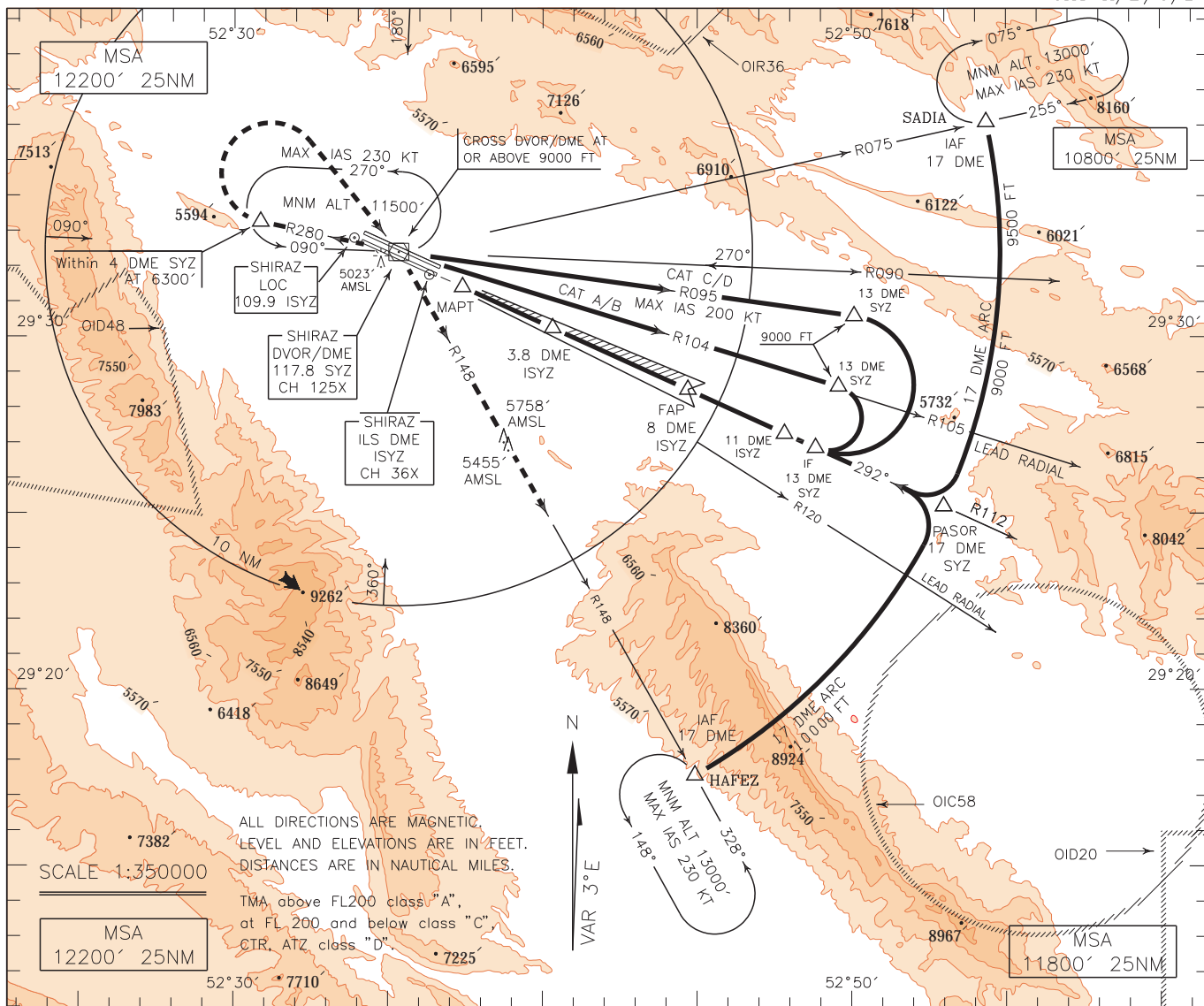

MISSED APPROACH: At MAPT (CAT A/B 0.9 DME ISYZ, CAT C/D 1 DME ISYZ) climb straight to DVOR/DME, then continue climb on RDL 280 to 6300 FT, then turn right (within 4 DME SYZ) to cross overhead DVOR/DME at or above 9000 FT, then intercept RDL 148 to join HLDG at 13000 FT. TA 13000'

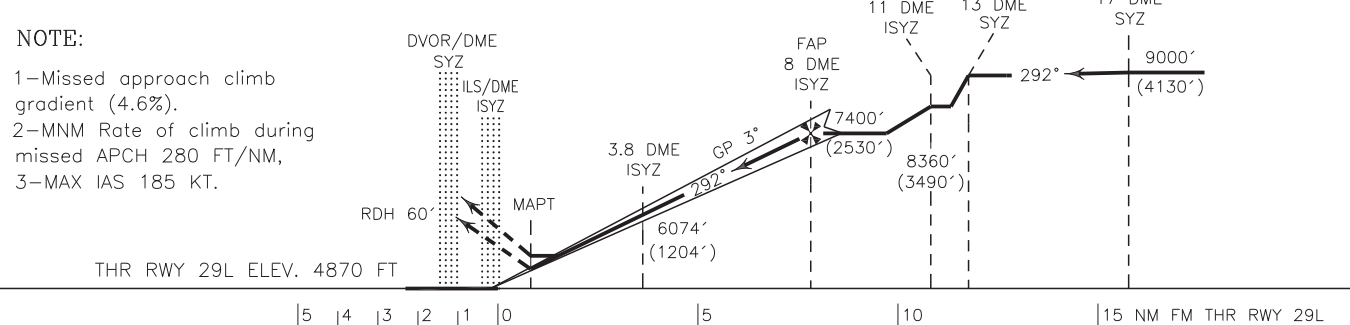

NOTE:

- Missed approach climb gradient (4.6%).
- MNM Rate of climb during missed APCH 280 FT/NM,
- MAX IAS 185 KT.

OCA(H)	A	B	C	D
Straight	5155' (285')		5174' (304')	
GP INOP	5400' (530')			
Circling	5600' (673')	6200' (1273')	6500' (1573')	

NOTE:

- Circling not authorized to the north of AD for ACFT CAT C/D.
- Contour intervals are to be selected at 990 FT (300 M).